

Engine output: **47.3 PS**  
Machine weight: **4,315 kg**

For Earth, For Life  
**Kubota**

# R065



# New standards in wheel loader performance and operator comfort.

It's all-new, inside and out, and ready for any job you give it. From Kubota, the well-known mini excavator brand, comes a new wheel loader designed get the job done faster and keep you working comfortably.



## KUBOTA ORIGINAL ENGINE

The R065 is powered by a robust 47.3 PS diesel engine. Built by Kubota, this reliable engine features low noise, low vibration, and low fuel consumption.

## SERVICEABILITY

Fast and easy access to all major service components ensures the R065 will be back on the job as quickly as possible.



# OPERATOR COMFORT

A new level of operator comfort helps you work more effie



## High-visibility cabin

All-new designed cabin features a fully enclosed glass to improve visibility in all directions. The full-glass left-side door and wide-opening right-side window provide clear views of the conditions outside. The rear of the cabin features rounded glass corners that, combined with the sloped bonnet, provide excellent visibility when reversing. Up front, a wide view and a redesigned Z-bar linkage configuration give you unobstructed views of the pallet fork tips from the driver's seat.

## • FROM THE OPERATOR VIEW POINT



**A**  
*Pallet fork view*



**B**  
*Quick Coupler connecting point*

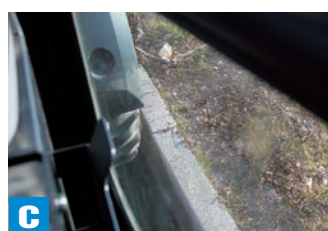

**C**  
*Side ground view*

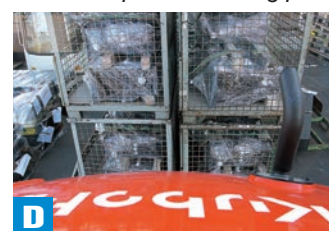

**D**  
*Back ground view*

efficiently and with less fatigue.



### Modern digital display

Bright and easy-to-read, the digital instrument panel tells you at a glance everything you need to know about the machine's functions and conditions. A full set of diagnostic indicators automatically monitor critical machine conditions, letting you concentrate on the job at hand.



### A Full-suspension seat

A full-size, full-suspension adjustable seat enhances operator comfort. The padded seat can be moved forward or back for optimum comfort.

### B Multi-function operating lever

You'll get more work done in less time with the R065's multi-function operating lever. All major loader functions—Speed Up/Down, Forward/Reverse, Neutral, and Differential Lock—are on a single lever that is easy to operate with just one hand. The 2-step Speed Up/Down buttons let you quickly change speeds and work at the optimum speed for the task at hand.

### C Tilt steering

With the flick of a lever, the steering wheel can be tilted up or down to the most comfortable and efficient position for drivers of all sizes.



## PERFORMANCE

You'll get the job done efficiently, thanks to the tough and reliable Kubota-built engine, excellent breakout force, superior maneuverability, and sure-footed stability in all types of working conditions.

## OPERATOR COMFORT

The spacious cabin's ergonomic layout is designed to keep you working comfortably from start to finish.

## SAFETY AND SECURITY

As always, security is paramount. A key-based anti-theft system keeps the R065 secure when you're not around. Six tie-down points ensure simple and secure transportation between sites.

KUBOTA WHEEL LOADER

# R065

# PERFORMANCE

**An optimum balance of power and function for the performance you need to get the job done efficiently.**



## **Working range**

A long dumping reach and high dumping clearance make all types of dumping jobs easy. The long dumping reach and high dumping clearance lets you dump into truck beds with ease, while the long dumping reach makes pallet fork operations faster and more efficient.

## **Differential Lock (100% on demand, front + rear)**

Should the wheels start to slip, simply press the differential lock switch to immediately engage both front and rear wheels. The result is positive, slip-free traction.

## **Arm tilt/parallel movement**

Transporting a full loaded pallet with the pallet fork, Kubota's arm tilt/parallel movement structure keeps the load upright and steady, even while raising or lowering the lift arm.

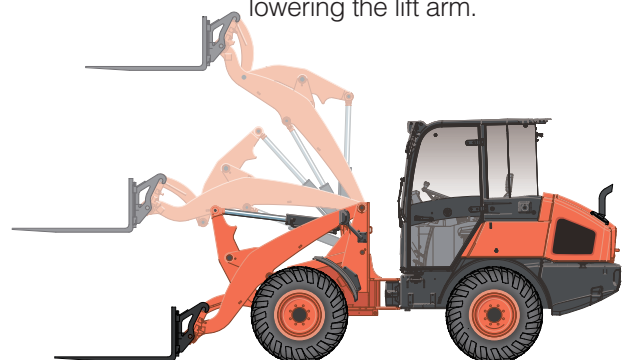

# SERVICE, SAFETY, AND SECURITY

A variety of service and safety features let you work safer and more securely.

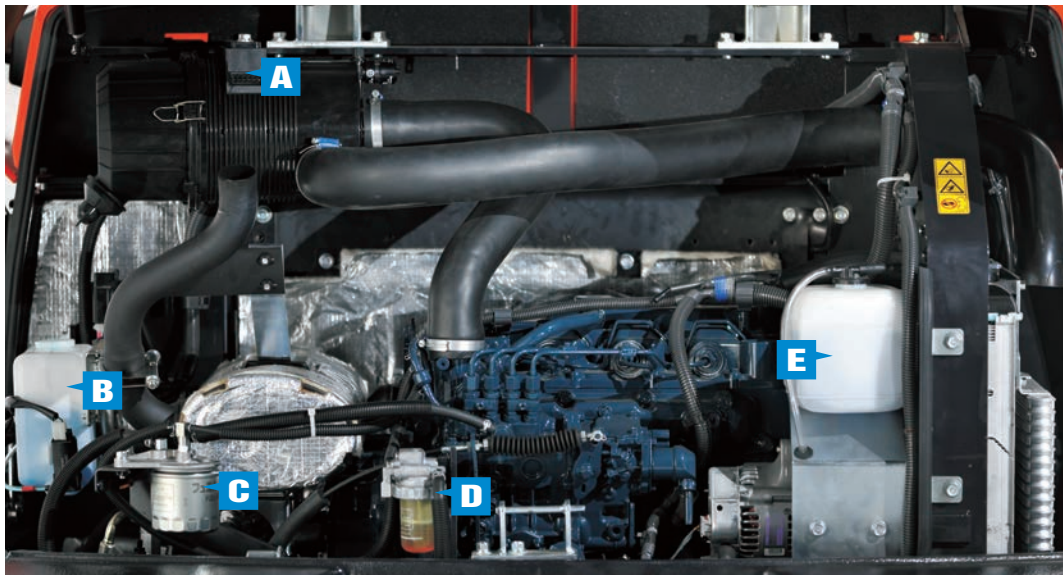

- A** Dual Element Air Cleaner
- B** Washer Tank
- C** Fuel Filter
- D** Water Separator
- E** Reserve Tank

## Easy maintenance

The engine bonnet at the rear opens wide, providing quick and easy access to the machine's main service areas. Items that require routine maintenance and service are within easy reach for fast and simple servicing. Quick-open panels on the right and left sides provide speedy access to the fuel refill (right side) and battery (left side). Other areas of the R065 are also easy to service and maintain.



## Kubota anti-theft system

Your R065 is protected by Kubota's reliable anti-theft system. Only programmed keys will enable the engine to start up. Attempting to start with an un-programmed key will activate the alarm. Its features include an alert to remind the operator to extract the key after operation, and an LED to alert potential thieves that the system is activated.

## Simple and secure transportation

With an overall height below 2500 mm, the R065 slips easily under road bridges for fast and safe transportation between job sites. Six tie-down points allow simple yet secure attachment to a truck bed for safety during transportation.



## Digital diagnostic indicators

A bright easy-to-read digital diagnostic indicator keeps you fully informed of critical loader and engine conditions.

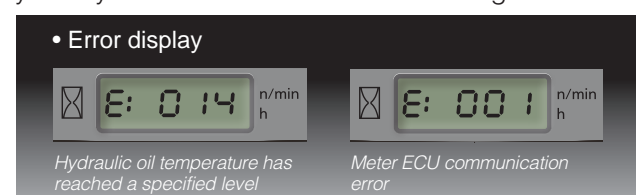

# Standard Equipment

## Engine/Fuel system

- KUBOTA original engine (Stage III A)
- Double-element air cleaner
- Fuel level indication buzzer

## Travel system

- Changeable 2 level-travel speeds
- Differential lock (100% on demand, front and rear)
- Wet type disc brake
- Negative brake (parking brake)

## Hydraulic system

- Hydrostatic transmission
- Multi function operating lever
- Hydraulic lock lever
- Inching and brake pedal (left)
- Attachment unlock switch
- AUX operating lever

## Cabin

- Cabin with heater
- 2 front working lights on the cabin
- Weight-adjustable suspension seat (fabric seat) with left arm rest and back rest
- Retractable seatbelt
- Digital panel with diagnosis function
- ROPS (Roll-over Protective Structure, ISO3471)
- FOPS (Falling Object Protective Structure, Level1, ISO3449)

- Radio installation (bracket, speaker, antenna, harness)
- Side mirrors
- Emergency exit hammer
- 12V power outlet
- Sun visor
- Tilt steering

## Canopy

- Weight-adjustable suspension seat (PVC seat) with left arm rest and back rest
- Retractable seatbelt
- Digital panel with diagnosis function
- ROPS (Roll-over Protective Structure, ISO3471)
- FOPS (Falling Object Protective Structure, Level1, ISO3449)
- Side mirrors
- 12V power outlet
- Tool storage space (under seat)
- Tilt steering

## Working equipment

- 2 Head lights (Headlights and Signal Lights)
- Hydraulic quick coupler
- Z-bar linkage with parallel movement
- Rear combination light (Turn signal, Tail light, Brake light, Back light)

## Safety

- 6 Tie down points
- Wheel chock
- Lift arm support
- Battery isolator
- Towing pin

## Others

- KUBOTA original anti-theft system
- Maintenance free battery
- Grease gun holder
- Cup holder



# Optional Equipment

## Cabin

- Beacon light
- Cabin with air conditioner

## Canopy

- Beacon light
- 2 front working lights

## Working equipment

- Safety valve for lift arm

## Others

- Bio oil
- Brake pedal (right)
- Shock absorber for lift arm
- Tool box
- Rear working lights
- Wire harness with socket (front, rear)
- Special color
- Various tires

Multipurpose: 12.5-20 317MPT (Alliance)  
 Industrial: 365/70 R18, SPT9 EM (Dunlop)  
 Agriculture: 340/80 R18, XMCL (Michelin)  
 • Various buckets and other attachment on request

# SPECIFICATIONS

Model		R065	
Operating weight (canopy/cabin)		kg	4165 / 4390
Bucket capacity		m <sup>3</sup>	0.65
Engine	Manufacturer		Kubota
	Model		Water-cooled V2607-DI-E3
	Horse power (ISO9249)	kW/rpm	34.8 / 2400
		PS/rpm	47.3 / 2400
	Number of cylinders		4
Displacement		cc	2615
Transmission	Type	Hydrostatic transmission	
Operational specifications with bucket	Tipping load, straight (ISO14397-1) (canopy/cabin)		kg 2880 / 3000
	Tipping load, full turn (ISO14397-1) (canopy/cabin)		kg 2400 / 2500
	Max. lifting capacity (ISO14397-2)		kN 27.4
	Breakout force (ISO14397-2)		kN 41.8
Operational specifications with pallet fork	Tipping load, full turn (ISO14397-1) (canopy/cabin)		kg 1900 / 2000
	Max. payload (EN 474-3) 80%		kg 1520 / 1600
	Max. payload (EN 474-3) 60%		kg 1140 / 1200
Traveling	Tire size		12.5-18
	Traveling speed	Forward	km/h 0 to 20
		Reverse	km/h 0 to 20
	Traction force		kN 29.1
	Front / rear axle		Differential lock 100% on demand
Angle of oscillation		Deg.	±8
Auxiliary circuit	Max. flow rate		ℓ/min 53.8
	Max. hydraulic pressure		MPa 18.6

Noise	Sound pressure level (LpA)(canopy/cabin) dB (A)	81 / 76
	Sound power level (LWA)(canopy/cabin) dB (A)	101 / 101
Capacity	Fuel tank	ℓ 70
	Hydraulic oil tank	ℓ 39
	Hydraulic oil tank, incl. hydraulic system	ℓ 55
	Engine oil	ℓ 9.0
	Front / rear axle oil	ℓ 4.5

Specifications are subject to change without notice.  
 Data is valid with general purpose bucket (standard width) and standard tire (12.5-18").  
 Operating weight is including 75kg operator

# BUCKET

Model		R065			
Type of bucket	General purpose bucket (standard)	General purpose bucket (wide)	4 in 1 bucket (standard)	4 in 1 bucket (wide)	
Capacity	m <sup>3</sup> 0.65	0.68	0.6	0.62	
Width	mm 1750	1820	1750	1820	
Weight	kg 309	317	478	489	
Bulk density	t/m <sup>3</sup> 1.9	1.8	1.8	1.7	
Recommend tire	12.5-18 317 MPT (Alliance) 12.5-20 317 MPT (Alliance)	365/70 R18 STP9 EM (Dunlop) 340/80 R18 XMCL (Michelin)	12.5-18 317 MPT (Alliance) 12.5-20 317 MPT (Alliance)	365/70 R18 STP9 EM (Dunlop) 340/80 R18 XMCL (Michelin)	

# PALLET FORK

Model		R065	
Fork length	mm	1000	
	mm	1200	



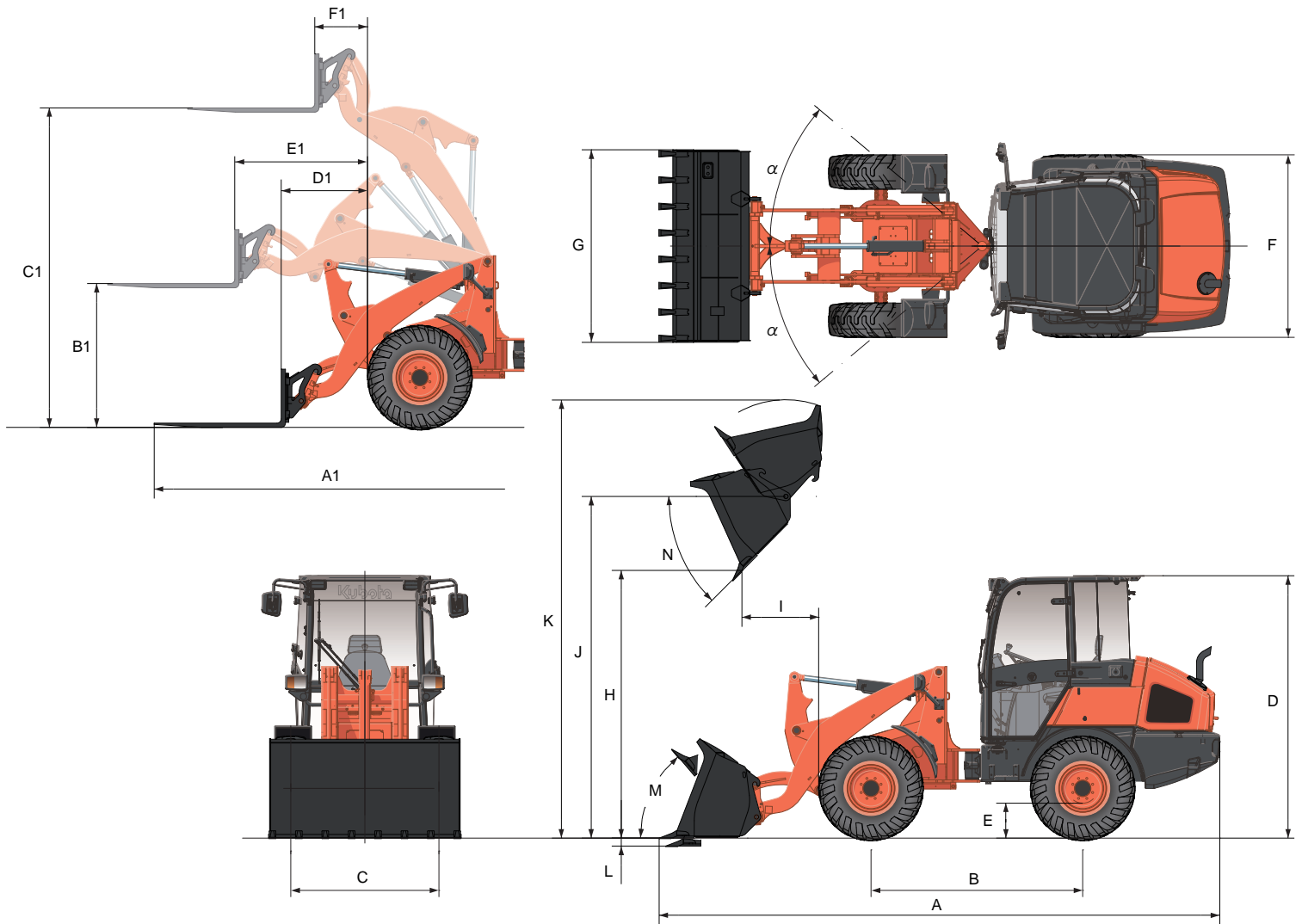

## WORKING RANGE

With Bucket Attachment			R065	
			General purpose bucket	
			Standard width	
Machine dimension	A	Overall length	mm	5195
	B	Wheelbase	mm	1950
	C	Tread	mm	1356
	D	Overall height (canopy / cabin)	mm	2460 / 2480
	E	Ground clearance	mm	330
	F	Overall width (outside of tires)	mm	1680
	G	Overall width (bucket)	mm	1750
	Working range	H	Dumping clearance (w/o teeth)	mm
I		Dumping reach (w/o teeth)	mm	700
J		Max. hinge pin height	mm	3230
K		Max. lifting height	mm	4070
L		Digging depth	mm	75
Others	M	Tilt back angle (at traveling position)	Deg.	50
	N	Dumping angle	Deg.	45
	$\alpha$	Articulation angle	Deg.	40
		Turning radius (track circle)	mm	3385

With Pallet Fork Attachment			R065	
Fork length			mm	1200
Working range	A1	Overall length	mm	5755
	B1	Height of forks at Max. reach	mm	1360
	C1	Height of forks at Max. height	mm	3020
	D1	Reach at ground level	mm	865
	E1	Max. reach	mm	1305
	F1	Reach at Max. height	mm	550

Specifications are subject to change without notice.  
Data is valid with general purpose bucket (standard width) and standard tire (12.5-18").

★ All images shown are for brochure purposes only.  
When operating the wheel loader, wear clothing and equipment in accordance to local legal and safety regulations.

**KUBOTA EUROPE S.A.S.**

19 à 25, Rue Jules - Vercruysse -  
Zone Industrielle - B.P. 50088  
95101 Argenteuil Cedex France  
Téléphone : (33) 01 34 26 34 34  
Télécopieur : (33) 01 34 26 34 99

**KUBOTA Baumaschinen GmbH**

Steinhauser Straße 100  
D-66482 Zweibrücken Germany  
Telefon : (49) 0 63 32 - 487 - 312  
F a x : (49) 0 63 32 - 487 - 101

<http://www.kubota-global.net>

Cat. No.8850-01-EU '14-05D.